

## Application research of deployable mechanism in deep-sea culture cage

Zixuan Zhang<sup>1</sup>, Lubin Hang<sup>2</sup>, Ziyu Liu<sup>3</sup>, Yiming Li<sup>4</sup>, Zizhong Ji<sup>4</sup>

<sup>1</sup>Department of Mechanical and Automotive Engineering, Shanghai University of Engineering Science, Shanghai, China

<sup>2</sup>Department of Mechanical and Automotive Engineering, Shanghai University of Engineering Science, Shanghai, China

<sup>3</sup>Department of Mechanical and Automotive Engineering, Shanghai University of Engineering Science, Shanghai, China

<sup>4</sup>Department of Mechanical and Automotive Engineering, Shanghai University of Engineering Science, Shanghai, China

Corresponding Author: Lubin Hang

---

**ABSTRACT:** As an important equipment of marine engineering, deep-sea cage plays a key role in the development of modern marine aquaculture. Aiming at the problems of large volume and inconvenient transportation of existing deep-sea cages, folding concept is introduced into the design of cages. The structural characteristics, working principle and developing trend of the deep-sea culture cage are analyzed in this paper. According to the characteristics of the deployable mechanism, such as the small volume of the deployable mechanism and the convenience of transportation, the deployable mechanism is applied to the design of the cage.

In this paper, A deployable primary and secondary cage for deep-sea culture is designed. The structure and working principle of the cage are introduced, and the advantages of the designed cage are analyzed.

**KEYWORDS:** deep-sea cage; deployable mechanism; primary and secondary; working principle

---

Date of Submission: 26-04-2019

Date of acceptance: 06-04-2019

---

### I. DEVELOPMENT STATUS OF DEEP-SEA CAGES

In recent years, with the increasing demand for aquatic products and the rapid development of fishing technology in marine fisheries, overfishing has occurred in the world's fish resources, and many precious fish species face the danger of extinction. However, there is a growing demand for fish products, which can not be satisfied by natural reproduction of fish. In order to ease this contradiction, countries all over the world are vigorously developing fish culture[1].

Cage culture is one of the main fish farming methods. Deep-sea culture cage is a kind of cage which can be used in deep sea area. It is a kind of breeding equipment and culture mode which has been developing rapidly in recent ten years. Even under very harsh sea conditions, it uses high technology to keep the cage structure system and its farmed fish safe and sound. Compared with traditional culture, deep-sea culture has greater economic, social and environmental benefits, which is a new direction for the development of culture industry in the future[2].

#### 1.1 Typical deep-sea cages at domestic and abroad

There are many forms of cage development up to now. According to the frame material of the cage, it can be divided into natural material cage, metal cage and synthetic material cage; according to the floating and sinking state of the cage, it can be divided into floating cage, caisson cage and lifting cage. Two typical deep-sea cages are described as following:

##### 1) Gravity full floating deep-sea cage[3]

Gravity cage is dependent on buoyancy and gravity to tighten the mesh and maintain a certain shape and volume. Under the action of current and wave, its net coat can fluctuate with the wave. This kind of cage has excellent flexibility and extremely easy to deform. Figure 1.1 shows a cage made of high density polyethylene (HDPE) tubes.

This kind of cage has many advantages such as simple structure, convenient daily operation and maintenance, easy to observe the breeding situation and low cost. However, under the action of strong current, the horizontal drift of net coat is serious, and the loss rate of cage volume is high.

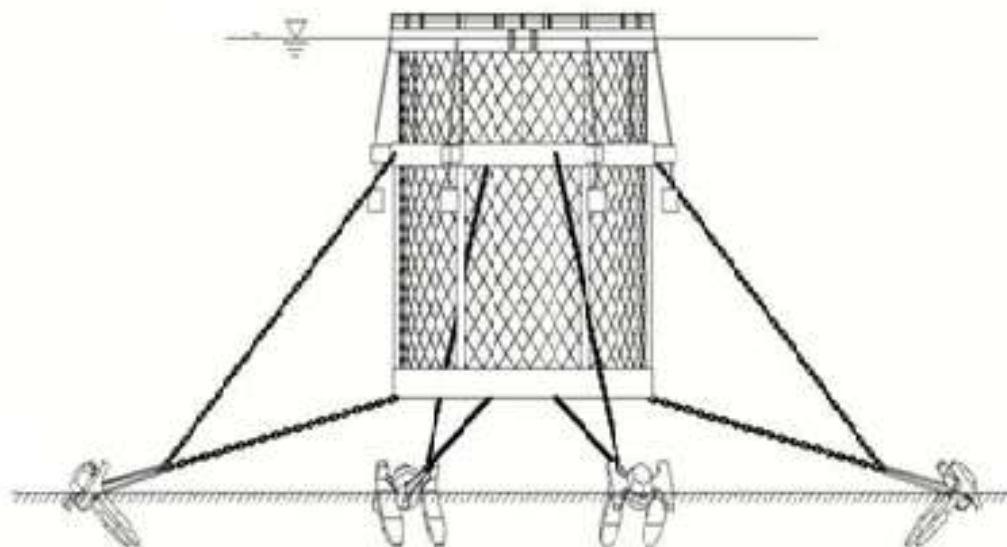

**Figure1.1 Gravity full floating cage**

## 2) Lifting deep-sea cage[4]

The lifting deep sea cage is a large deep sea cage that can be raised and lowered by high density polyethylene, as shown in Figure 1.2. This kind of cage is composed of a cage frame which can be submerged into water, the intake and exhaust control system, cylindrical pipe, intermediate joints, netting mesh and balance weights. The cage is able to withstand the impact of wind and current to some extent.

Lifting deep-sea cage has extremely high disaster prevention capability. Before the strong winds come, the cage can dive to a certain depth to avoid the impact of wind and waves. However, the up and down operation of the cage increases the complexity of the operation and the design difficulty, and the cost of this kind of cage is high.



**Figure1.2 Lifting deep sea cage**

## 1.2 Developing trend of deep-sea cages at domestic and abroad[5-7]

At present, countries around the world have developed more than a dozen deep-sea-cages with excellent performance. Overall, the development of deep-sea cages presents the following characteristics :

- (1) The size of the cage is becoming larger and larger. The yield of fish of a single cage can be 250 tons, which greatly reduces the cost of breeding and improves economic benefits.

- (2) Strong resistance to wind and waves. The deep-sea cages developed by the many countries can resist the wave of 5 to 10 meters. In terms of deformation resistance, the breeding volume ratio is maintained above 85% under severe conditions.
- (3) Wide application of new materials and new technologies. New materials such as special stainless steel are introduced in the design of cages, various anti-fouling technologies are adopted to improve the structural strength of the cage and to prolong the service life of the cage.
- (4) High degree of automation. With the application of computer integration and automatic control technology, the automated culture management technology of cages has been rapidly developed, such as the Swedish FARMOCEAN cage which can be completely operated without manual operation.
- (5) Emphasis on environmental protection by using systems engineering methods. The cage and its environment are studied as a system, combined with computer simulation technology for simulation analysis. By incorporating environmental protection concepts, and minimizing the pollution and impact of cage culture on the environment, the cages can achieve sustainable development mode .

## **II. EXHIBITION OF DEPLOYABLE MECHANISMS**

### **2.1 Deployable mechanism**

The deployable mechanism is a mechanism that can realize obvious structural changes by changing the topological configuration of the mechanism. The deployable mechanism has been widely concerned and applied due to its advantages of small mass, small size, convenient storage and transportation[8].

At present, the deployable mechanism is widely used in the field of aerospace, architecture, medical and other fields, which can be used as space extension arm, deployable antenna, deployable roof, deployable bridge, vascular stent in biological medicine and so on. With strong mobility and short construction period, the developable mechanism plays an important role in temporary or semi-permanent structures. After natural disasters such as typhoon, flood, earthquake, etc., developable institutions can adapt to different environments, in the compact folded state by cars, planes and other transport to emergency disaster areas, quickly assembled or formed on the ground, while providing a variety of refuge space without losing the stability of the structure, so that the victims get resettlement. Similar concept of developable mechanism can be applied to rapidly assembled or expanded Bridges, communication towers and other structures. As shown in figure 2.1, a deployable rolling bridge is 12 meters long, which can be folded into a regular octagon when it is not suitable for handling and moving[9].

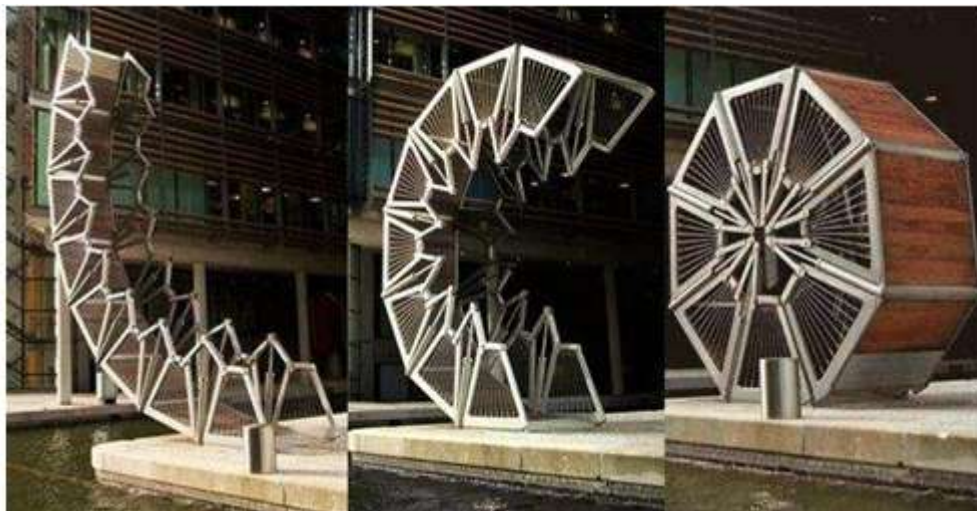

**Figure 2.1 Deployable Bridge**

### **2.2 Advantages of deployable mechanism in the application of cage**

Deployable mechanism is widely used and has many advantages. Its advantages in cage design can be shown as follows:

- (1) Adopt deployable mechanism to design deep-sea cage, which can greatly save the space and facilitate transportation after deployable.
- (2) In the using process of the cage , if it is necessary to replace the net cage clothes or catch fish ,the cage can be folded and pulled out of the water, greatly reducing the difficulty of the work.
- (3) When the deployable mechanism is foled partially, the gravity center of the cage will turn over, and the cage body will swing in water, which can effectively remove the pollutants adhering to the surface of the net clothes and realize the self-cleaning function of the net cage.

### III. THE DESIGN OF DEPLOYABLE DEEP-SEA CAGE

The deep-sea cage is mainly composed of internal and external cage frame, buoyancy device, anchor device and net clothing. In the following paragraphs, we will introduce the function of each part of the cage and the working mode of the designed cage. Deployable deep-sea culture cage is shown in the figure 3.1.

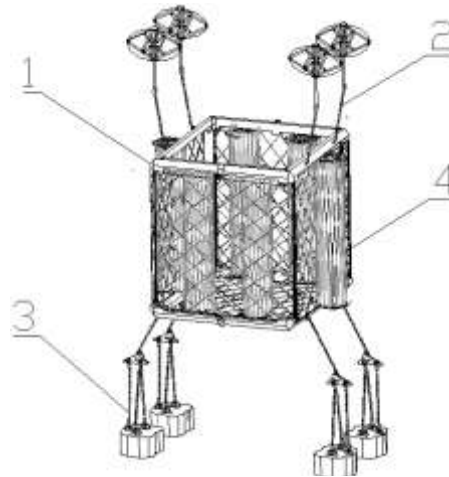

1-framework 2- Buoyancy device 3- Anchoring device 4-net clothing  
FIG.3.1 Deployable deep-sea culture cage

#### 3.1 Internal and external framework

The external frame of the cage is composed of 6 rigid material bars, which are 2 long bars and 4 short bars. Each bar is connected by a hinge, which expands to form a rectangular frame with deployable function. A hook ring is locked at the ends of the bar, which can be connected with the buoyancy device; The center part of the short bar has grooves at both ends, and the internal frameworks can be fixed with a bolt. Two hook grooves are arranged on the inclined surface of each member, which can be connected to the net clothing. FIG. 3.2 is a schematic diagram of frame expansion.

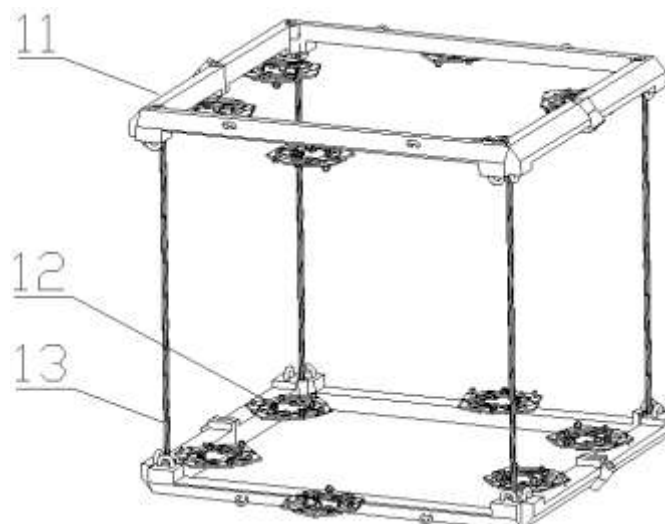

11-external framework 12-internal framework 13-steel cable  
FIG.3.2 Schematic diagram of complete expansion of internal and external frame

The internal framework is assembled by 12 triangular blocks. The external six blocks are isosceles triangular blocks with a vertex angle of 120 degrees. Each of the three vertices has a round hole for assembly with other triangular blocks. A regular hexagon can be formed after the subframe is fully expanded. In order to make the central area of the subframe large enough, a semicircle is cast for the center of the circle at the bottom center of the internal triangle block. Since the 12 triangular blocks of the sub-frame are interlaced, a hook ring is mounted on each upper triangular block to prevent interference, and a small mesh garment can be connected to it. FIG. 3.3 is a schematic diagram of internal frame expansion.



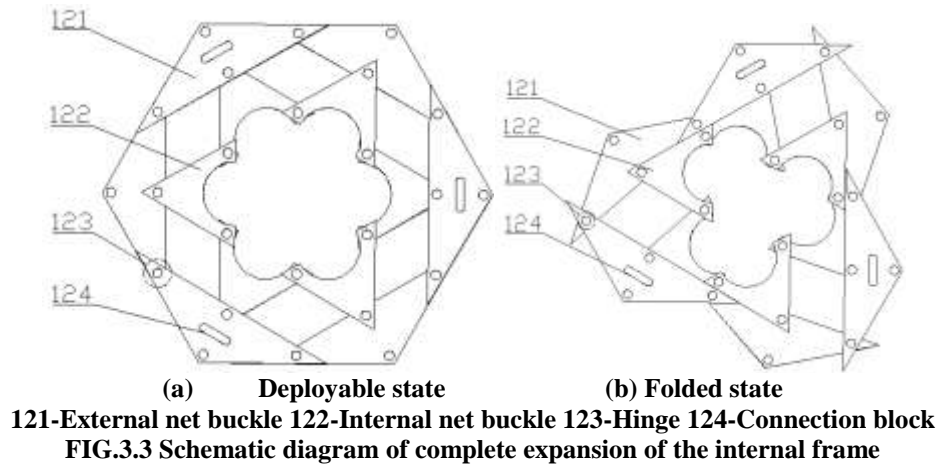

### 3.2 Buoyancy device

The buoyancy device adopts the structure of retractable (umbrella type). In order to adapt to the deployable cage, the design of the buoyancy is deployable and detachable. (as a pendant, through the cage on the hook link and the air bags can provide buoyancy. The expansion state is shown in figure 3.4 and the contraction state is shown in figure 3.5.

It is necessary to move the sliding pair up and down the center cylinder to achieve the mechanism expansion and contraction. According to this feature, this scheme chooses to use the screw nut drive to make the sliding pair move. The nut is fixed, and the screw is driven by motor to move the nut pair.

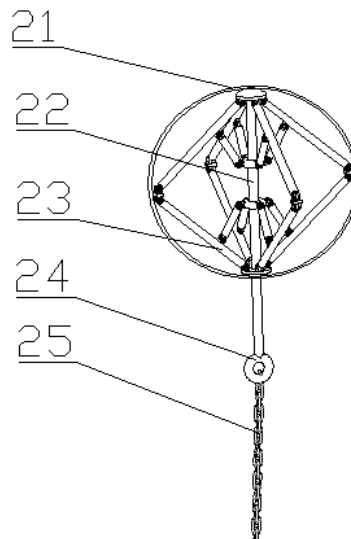

21-Cover 22-Center column 23-The deployable support machine 24-Hook 25-SSteel chain

**FIG. 3.4 Buoyancy device**

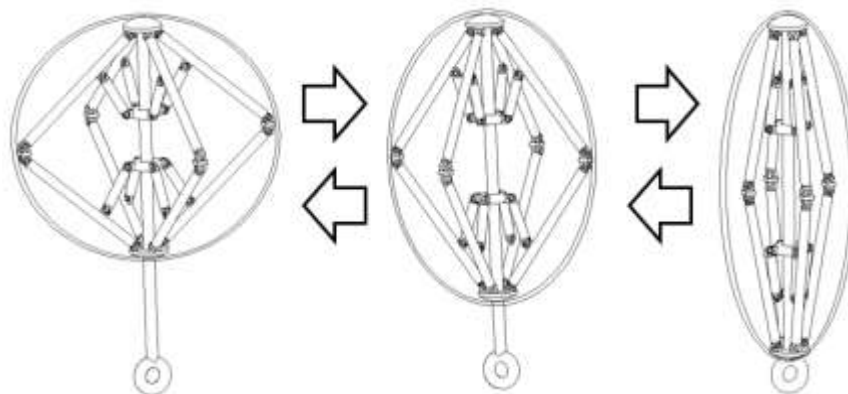

**FIG.3.5 The adjustment process of the buoyancy device**

### 3.3 Anchoring device[10]

The anchoring device adopts the scheme of normal load-bearing gravity anchor. Compared with traditional towed anchor and pure gravity anchor, the normal load-bearing gravity anchor has the following prominent characteristics:

(1) normal force

Under normal working conditions, the load (uplift force) direction of the normal bearing anchor is parallel to the external normal direction of the plane of the anchor plate, so it is very suitable for the taut cable mooring system. The performance of the anchor is very similar to that of a normally stressed plate (or block) embedded in the soil.

(2) high bearing capacity

Due to its unique normal force characteristics, the gravity anchor has a very high bearing capacity. According to the preliminary estimation, the normal bearing gravity anchor can bear more than 100 times of its own gravity, and the ultimate pulling force of the anchor can reach 3.5 times of the installed load, which can safely and firmly fix the cage. Anchoring device of deep-sea cage is shown in the FIG.3.6. Due to its unique normal force characteristics, the gravity anchor has a very high bearing capacity. According to the preliminary estimation, the normal bearing gravity anchor can bear more than 100 times of its own gravity, and the ultimate pulling force of the anchor can reach 3.5 times of the installed load, which can safely and firmly fix the cage. Anchoring device of deep-sea cage is shown in the FIG.3.6.



31-Normal bearing bracket 32-Steel chain 33-The anchor  
FIG. 3.6 Fixing device of deep sea cages

### 3.4 Net clothing

The whole net clothing box is mainly composed of net cover net clothing, net wall net clothing, net bottom net clothing, net clothing support using flexible materials. The internal frame net clothing and the external frame net clothing is shown in the FIG.3.7.

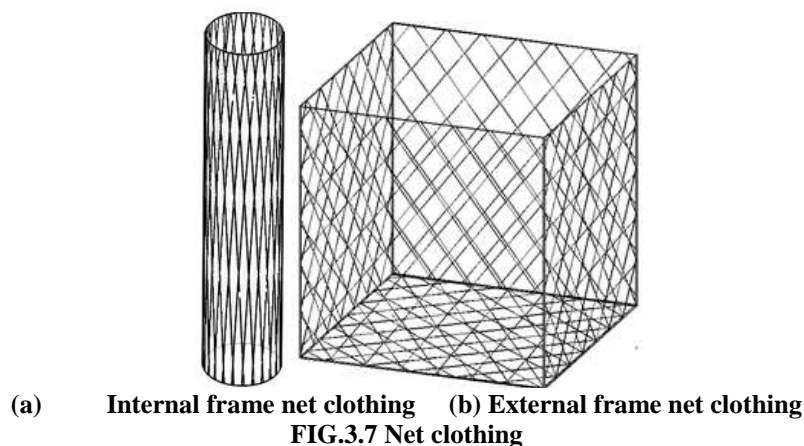

The seabed environment is complex and changeable, Net clothing supporting by rigid materials are prone to corrosion and other issues. Therefore, flexible materials are used. Using flexible ABS plastic to make the net clothing because flexible ABS plastic is a very large and widely used polymer and it has excellent mechanical properties of toughness, hardness, and phase balance. Flexible ABS has excellent mechanical properties, excellent impact strength and can be used at extremely low temperatures. Flexible ABS is not affected by water, inorganic salts, alkalis and various acids.

### **3.5 Working mode of the cage**

As shown in Figure 3.8, the internal and external frames of the cage are fully deployed. The complete undeployable process is as follows: firstly, the external frame is deployed, and after the external frame is completely deployed, each internal frame is deployed in turn, and after the internal frame is fully expanded, the internal and external frames of the cage reach the fully expanded mode.



**FIG.3.8 The internal and external frames of the cage are fully deployed**

As shown in Figure 3.9, the frame inside the cage is completely closed and the external frame is fully expanded. This mode consists of two processes. The semi-expansion process and the semi-collection process are respectively. The semi-expansion process is to first fully expand the external frame, and the internal frame remains in the collapsed state. The semi-collapsing process is: firstly, each internal frame is gathered, so that each internal frame is completely closed, and the external frame is still expanded.

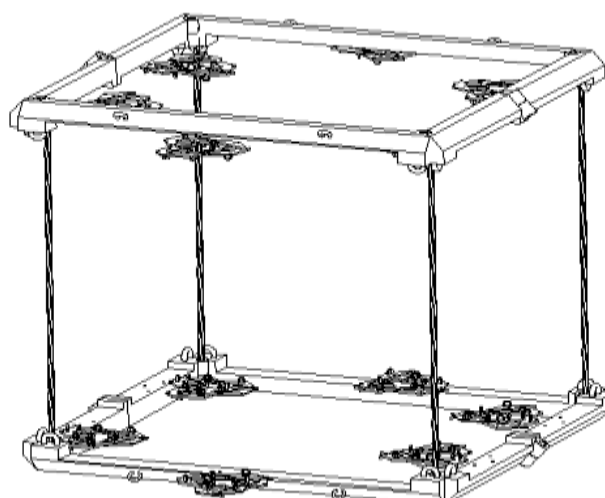

**FIG.3.9 The frame inside the cage is completely folded and the external frame is fully deployed**

As shown in Figure 3.10, the internal and external frames of the cage are completely collapsed. The complete deployable process is as follows: firstly, each internal frame is gathered, the internal frame is completely gathered, and then the external frame is gathered, and the external frame is completely closed, and the internal and external frames of the cage reach a complete deployable mode.

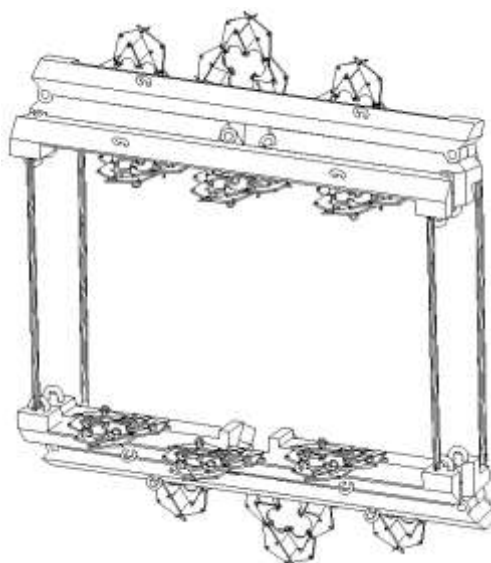

**.3.10 The internal and external frames of the cage are completely folded**

#### **IV. CONCLUSION**

The common parts of deep-sea culture cages are mostly one-piece design. This kind of design makes the cage basically fixed in the actual use process. Once the cage is installed and fixed below the water surface, it is hard to clean and fishing,. How to carry out diversified breeding in large cages is the current development trend of cage culture, and its development prospects are broad.

The deployable cage overcomes the shortcomings of the large size of the fixed cage and the inconvenience of storage and transportation. The folded cage has a small storage space, easy to transport and assembled quickly. The design of primary and secondary cage solves the problem of single breeding species and realizes diversified farming in each sub-cage. The prospect of cage culture is broad and has great research significance.

#### **REFERENCES**

- [1]. Advances in deep sea cage culture technology [J]. ChaohuiZhang,JiaoriCong,K.φMidling. Chinese aquatic products. 2001(04)
- [2]. Zhenzhen Zhang. The Status Quo, Issues and Foreign Experiences of Deep Sea Aquaculture Equipment of China [A]. Research Institute of Management Science and Industrial Engineering. Proceedings of 2018 2nd International Conference on Social Sciences, Arts and Humanities (SSAH 2018) [C].Research Institute of Management Science and Industrial Engineering: Computer Science and Electronic Technology International Society,2018:5.
- [3]. Beveridge, M.C.M. 1987. Cage aquaculture. Fishing news books Ltd., Oxford.Wang Yan-Duo.Research on Initial Penetration of the Vertically Loaded Anchor.Tianjing University.2008.
- [4]. Vertically Loaded Anchors for Deepwater Applications. J.D. Murff,M.F.Randolph,,S.Elkhaib.Frontiers in Offshore Geotechnics.2005.
- [5]. WEI You-Hai, Zhang Ming. Using deep-sea cage culture technology to promote sustainable fisheries development. Scientific Fish Farming. 01 phase of 2013.
- [6]. JING Fa-Qi. Development status of deep-sea cage culture. Fisheries Science and Technology. 03 phase of 2010.
- [7]. SONG Rui-Yin, ZHOU Min-Long, LI Yue, ZHANG Hui-Di,LINZuan. Research progress on key technologies of deep-sea cage culture equipment. Mechanical Engineer. 10 phase of 2015.
- [8]. Ye Chunhe, Jiang Zeming. The development of cage farming technology in China from the perspective of Chinese patent [J]. Qilu Fisheries, 2003 (08): 10 / 13.
- [9]. McConson, Xu Hao, XueChanghu, Gu Weidong, Zhang Wenbing, Li Zhaojie, Yu Bo. Strategic Research on opening up New Space for far-reaching Aquaculture in China [J]. China Engineering Science, 2016, 18 (03): 90 × 95.

"Lubin Hang" Application research of deployable mechanism in deep-sea culture cage"  
International Journal of Research in Engineering and Science (IJRES), vol. 07, no. 1, 2019, pp.  
14-21